

| REVISIONS | | | |
|-----------|-------------|------|----------|
| REV. | DESCRIPTION | DATE | APPROVED |
| | | | |

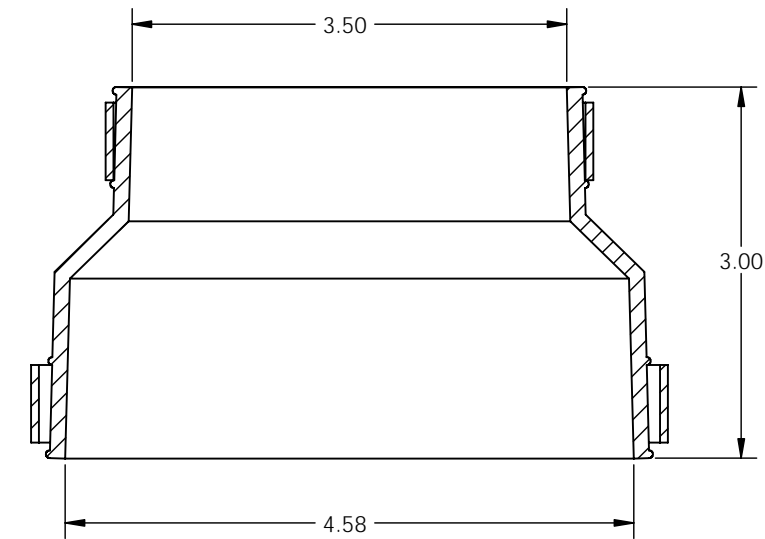
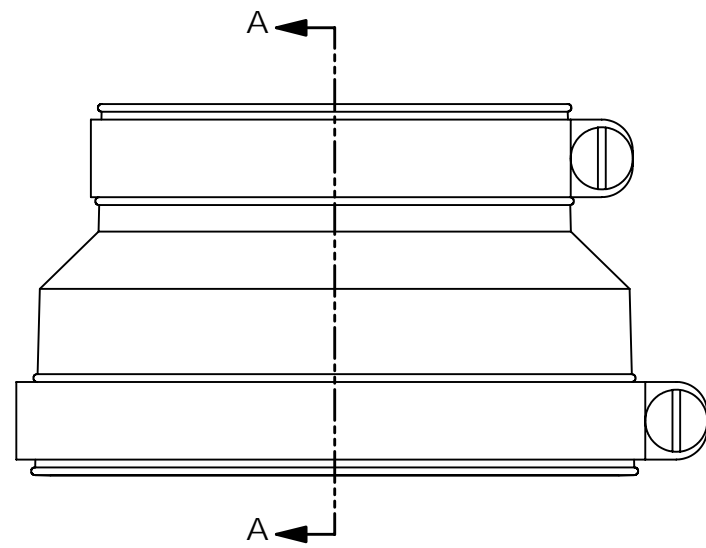
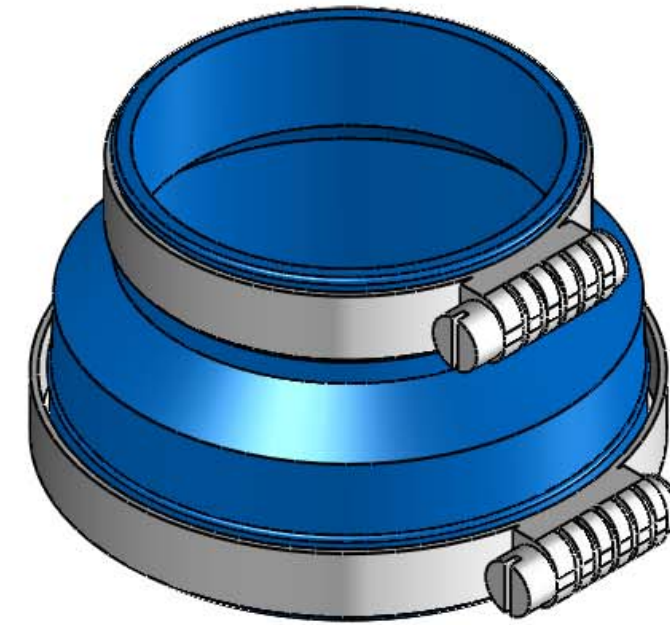
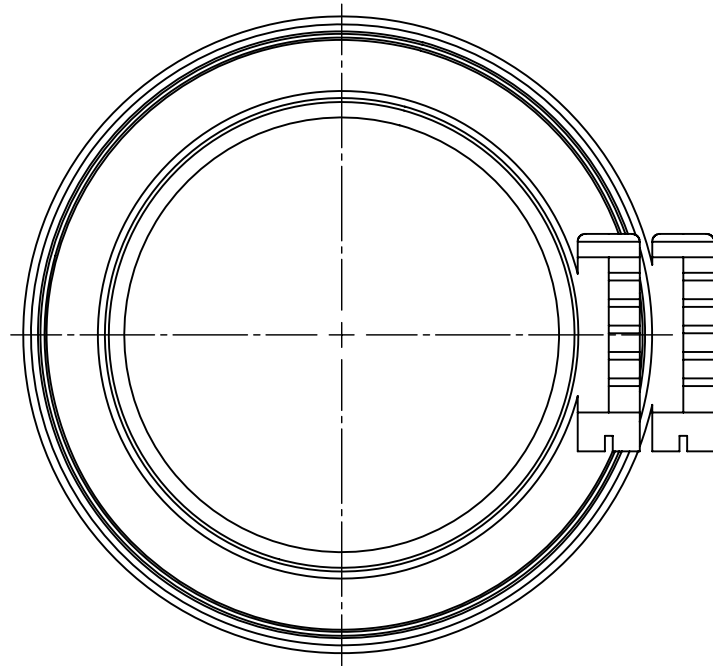

SECTION A-A

PROPRIETARY AND CONFIDENTIAL
 THE INFORMATION CONTAINED IN THIS DRAWING IS THE SOLE PROPERTY OF **BLUELINE TECHNOLOGIES LLC**. ANY REPRODUCTION IN PART OR AS A WHOLE WITHOUT THE WRITTEN PERMISSION OF **BLUELINE TECHNOLOGIES LLC** IS PROHIBITED.

| | | |
|-----------------------------|-----------|------------|
| UNLESS OTHERWISE SPECIFIED: | NAME | DATE |
| DIMENSIONS ARE IN INCHES | DRAWN | DH 12/1/04 |
| TOLERANCES: | CHECKED | |
| FRACTIONAL ± | ENG APPR. | |
| ANGULAR: MACH ± BEND ± | MFG APPR. | |
| TWO PLACE DECIMAL ± | Q.A. | |
| THREE PLACE DECIMAL ± | COMMENTS: | |
| MATERIAL | | |
| FINISH | | |
| DO NOT SCALE DRAWING | | |



| | | |
|-------------|-------------|--------------|
| TITLE: | | |
| PER 4.5x3.5 | | |
| SIZE | DWG. NO. | REV |
| C | PER 4.5x3.5 | |
| SCALE: 1:1 | WEIGHT: | SHEET 1 OF 1 |