

Retro Fit Lid Installation Instructions (For Poly Sumps)

STEP 1

If required, trim or cut the sump collar top to a smooth and level finish. Sand the surface to prepare it for bonding and thoroughly clean the surfaces with Acetone. (*When working in or around a sump, never use tools that could produce a spark.*)



STEP 2

Apply a liberal bead of POLYFUSION to the rim of the sump collar. Ensure that the entire collar rim is covered with bonder.

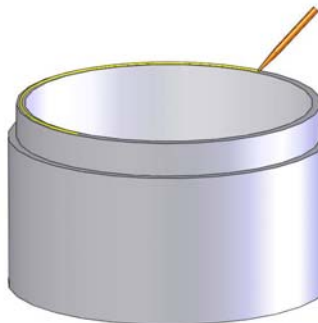

STEP 3

Install the adapter ring onto the collar rim and apply weight to the top of the adapter to ensure a tight seal against the collar rim. Allow two hours for POLYFUSION to cure before proceeding to the next step.

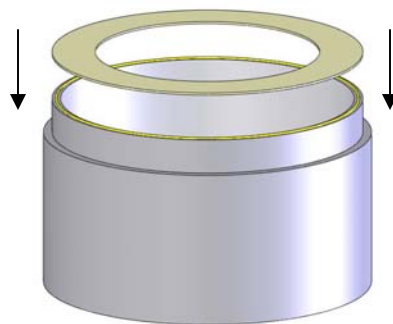

STEP 4

Apply a bead of POLYFUSION to the inside seam of the adapter ring and sump collar.

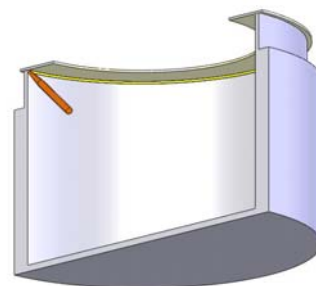

STEP 5

Position the sump top onto the top of the adapter ring and trace a line for guidance when applying the POLYFUSION.

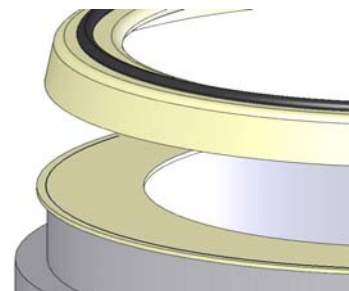

Retro Fit Lid Installation Instructions (For Poly Sumps)

STEP 6

Following the guidance line, apply a liberal bead of POLYFUSION to the top of the adapter ring.

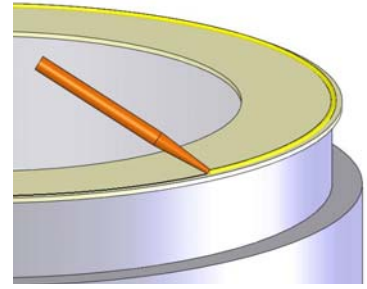

STEP 7

Install the sump top onto the top of the adapter ring and apply weights while the bonder cures.



STEP 8

Apply a liberal bead of POLYFUSION to the outside seam between the sump top and the adapter ring. Once this is applied, smooth out the bonder along the seam to ensure there are no voids and clean up any excess bonder. Allow 24 hours for POLYFUSION to fully cure.

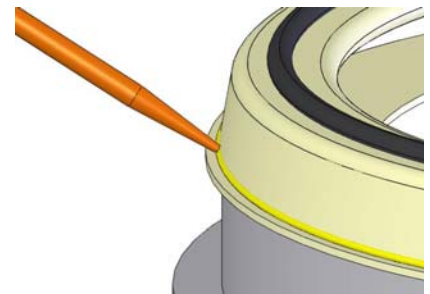

STEP 9

Install the watertight lid down onto the sump top.

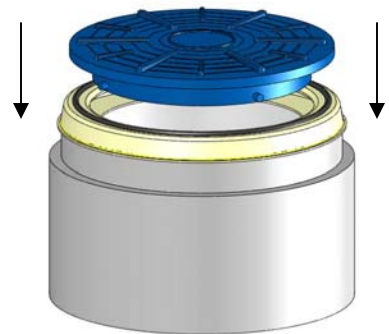

STEP 10

Give the watertight lid a slight turn clockwise to lock it down and to ensure a watertight seal.

