

SBTCIF Split Repair Boots for Total Containment

The SB Series Pellethane Split Repair Boots are used inside the sump to repair Total Containment Bulkheads and Conduit Penetrations. Repair boot threads directly onto existing bulkhead. Fittings can also be used to seal off ducting to allow re-pipe with double wall pipe.

FEATURES & BENEFITS

- Unique threaded fittings for repair of all TCI applications
- Attaches to existing bulkhead to avoid clearance issues.
- Low profile design leaves room for secondary test boot
- Boots are filled for added security
- Boots are split for installation after re-pipe

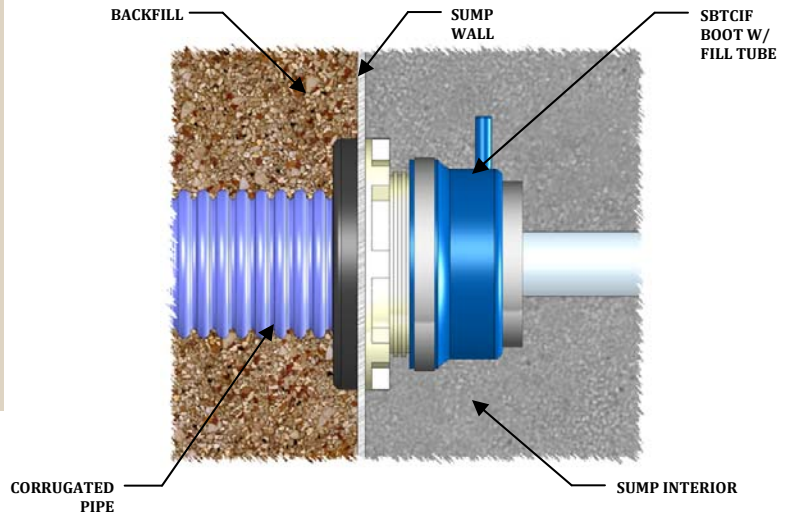

Fitting Type	Ring Dimensions	Part Number	Description
TCI	Fits existing TCI Fittings	SBTCIF2.4x1.4	Split Repair Boot for Total Containment electrical conduit entry fittings 2.4x1.4 w/ Fill Tube
		SBTCIF2.61x1.4	Split Repair Boot for Total Containment electrical conduit entry fittings 2.61x1.4 w/ Fill Tube
		SBTCIF6.8x2.0	Split Repair Boot for Total Containment entry fittings. 6.8x2.0 w/ Fill Tube
		SBTCIF6.8x2.25	Split Repair Boot for Total Containment entry fittings. 6.8x2.25 w/ Fill Tube
		SBTCIF6.8x2.5	Split Repair Boot for Total Containment entry fittings. 6.8x2.5 w/ Fill Tube
		SBTCIF6.8x2.7	Split Repair Boot for Total Containment entry fittings. 6.8x2.7 w/ Fill Tube
		SBTCIF6.8x3.0	Split Repair Boot for Total Containment entry fittings. 6.8x3.0 w/ Fill Tube
		SBTCIF6.8x3.5	Split Repair Boot for Total Containment entry fittings. 6.8x3.5 w/ Fill Tube
		SBTCIF6.8x4.5	Split Repair Boot for Total Containment entry fittings. 6.8x4.5 w/ Fill Tube