

TCI Split Repair with Air Test Installation Instructions

(For stopping water intrusion problems in damaged TCI fittings)

STEP 1

Identify the damaged TCI fitting and determine the leak point. If the leak is at the housing flange, loosen the nut and reapply a bead of either Parasealant 626, or Bostik 1100FS between the sump wall and the nut. Reinstall the nut.

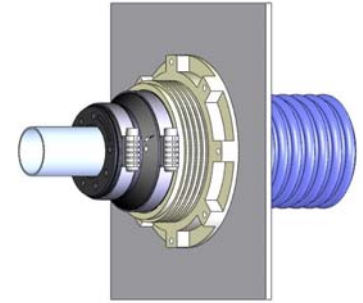

STEP 2

Using a knife, cut the damaged boot along the edge of the lower clamp. Remove the outer clamp and the insert from the old fitting.

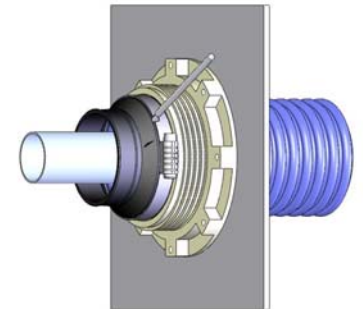

STEP 3

Remove the cut portion of the boot and the old insert carefully from the pipe and discard.

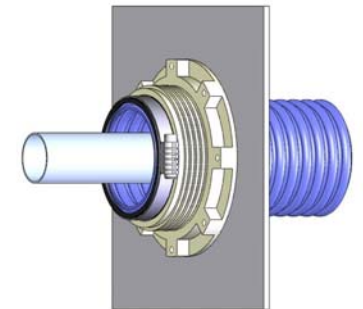

STEP 4

Install the TCI repair boot around the pipe and apply a liberal bead of Blue Seal Glue along both edges of the seam. Push the seam together lightly or clamp lightly until the seam is cured. (Blue Seal Glue typically will cure enough to hold the fitting together within five minutes and fully cures within 40 minutes.)

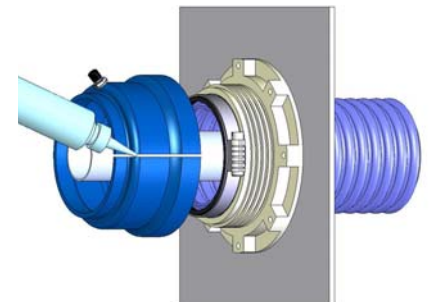

STEP 5

Apply a bead of Blue Bond 801 around the housing threads and thread the repair boot onto the housing.

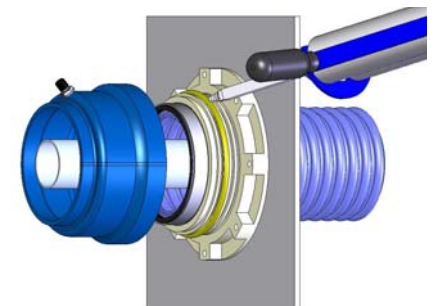

TCI Split Repair with Air Test Installation Instructions

(For stopping water intrusion problems in damaged TCI fittings)

STEP 6

Install the split insert around the pipe and apply a liberal bead of Blue Seal Glue along the seam and lightly hold or clamp until cured.

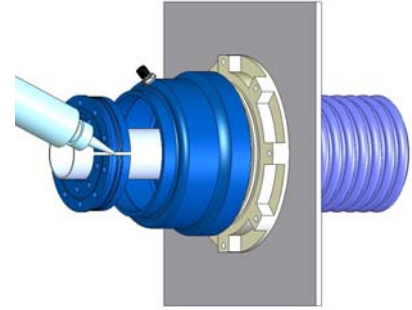

STEP 7

Install the insert into the repair boot.

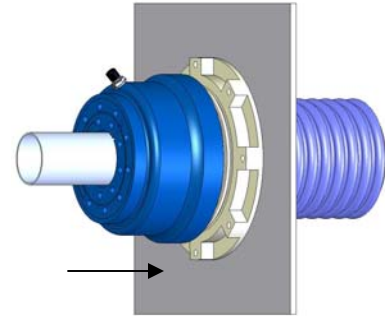

STEP 8

Install both band clamps and tighten to 65 inch lbs.

