

## SR SERIES PELLETHANE SPLIT REDUCERS / TEST REDUCERS

The SR Series Pellethane Split Repair Reducers and Test Reducers are used to replace failed and deteriorating secondary test boots without breaking the lines. All boots come with band clamps and are available with and without air test valves.

- FEATURES & BENEFITS**
- The SR SERIES Reducers and Test Reducers are used to replace cracked or leaking reducers on existing piping
  - Installs quickly – full cure in 40 minutes
  - Available offset, when primary pipe isn't concentric with secondary pipe
  - Made from fuel resistant pellethane material
  - No need to disconnect pipe
  - Able to test at 5-6 psi
  - UL Listed

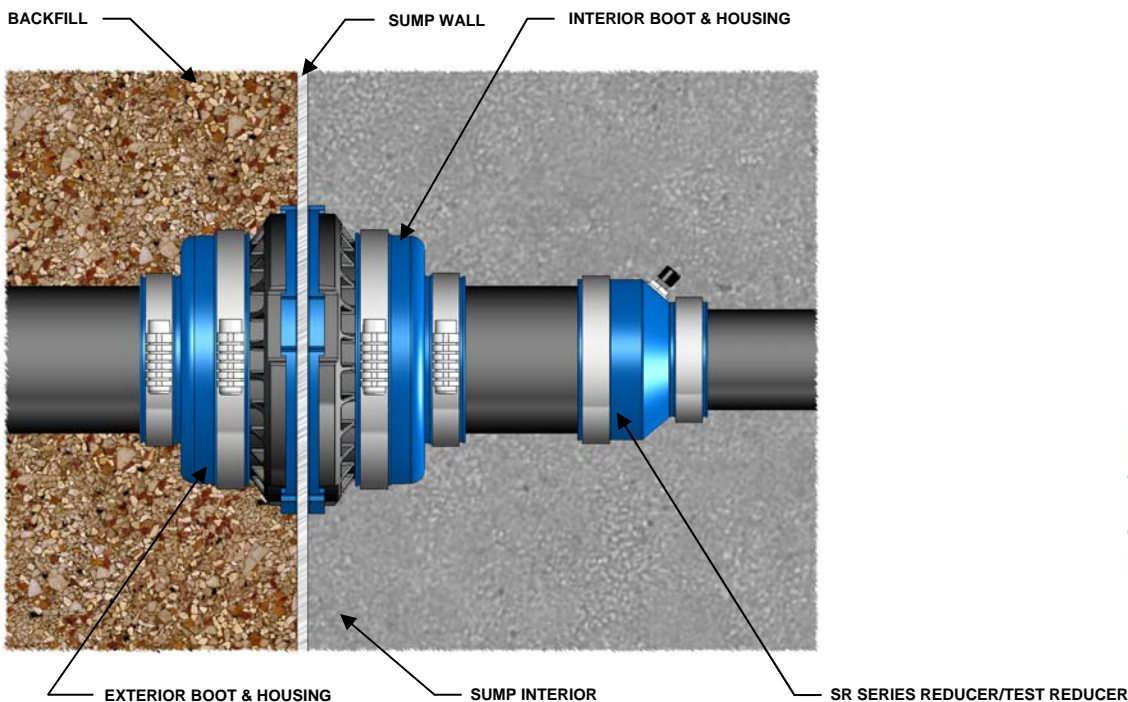

ALL PELLETHANE REDUCERS UL LISTED  
FILE NUMBER MH28727



FLAMABLE AND COMBUSTIBLE  
LIQUID TANK ACCESSORIES

