

## TCIF Non-Split Repair Boots for Total Containment

The SB Series Pellethane Split Repair Boots are used inside the sump to repair Total Containment Bulkheads and Conduit Penetrations. Repair boot threads directly onto existing bulkhead. Fittings can also be used to seal off ducting to allow re-pipe with double wall pipe.

### FEATURES & BENEFITS

- Unique threaded fittings for repair of all TCI applications
- Attaches to existing bulkhead to avoid clearance issues.
- Low profile design leaves room for secondary test boot
- Boot are filled for added security
- Great for re-pipes

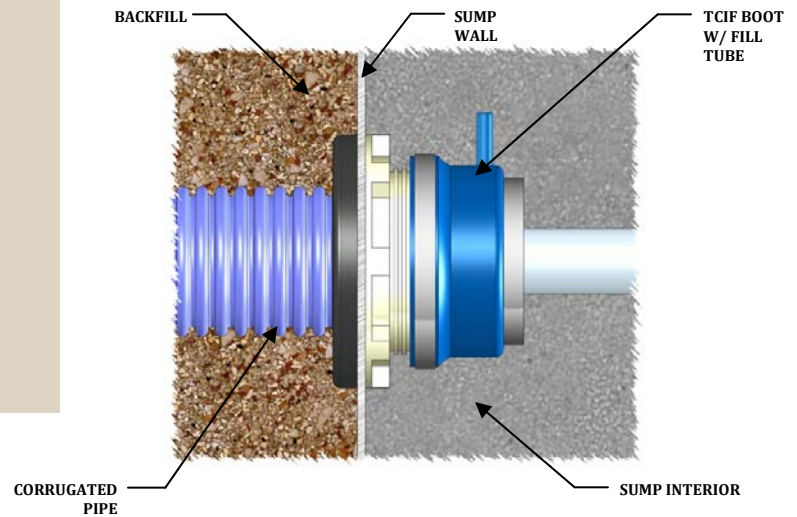

Fitting Type	Ring Dimensions	Part Number	Description
TCI	Fits existing TCI Fittings	TCIF6.8x2.0	Non-Split Repair Boot for Total Containment fittings. 6.8x2.0 <b>w/ Fill Tube</b>
		TCIF6.8x2.25	Non-Split Repair Boot for Total Containment fittings. 6.8x2.25 <b>w/ Fill Tube</b>
		TCIF6.8x2.5	Non-Split Repair Boot for Total Containment fittings. 6.8x2.5 <b>w/ Fill Tube</b>
		TCIF6.8x2.7	Non-Split Repair Boot for Total Containment fittings. 6.8x2.7 <b>w/ Fill Tube</b>
		TCIF6.8x3.0	Non-Split Repair Boot for Total Containment fittings. 6.8x3.0 <b>w/ Fill Tube</b>
		TCIF6.8x3.5	Non-Split Repair Boot for Total Containment fittings. 6.8x3.5 <b>w/ Fill Tube</b>
		TCIF6.8x4.5	Non-Split Repair Boot for Total Containment fittings. 6.8x4.5 <b>w/ Fill Tube</b>